

S - 62 - AA (ULLY POWERED STACKER-ADJUSTABLE FORKS & ADJUSTABLE LEGS)

Specifications

Model # S-62-AA
 Capacity (UDL): 2,000 lbs
 Lift height: 62"
 Lowered height: 2¹/₈"
 Adjustable Forks & adjustable legs
 Single Mast
 Safety Shield
 Overall mast height: 78"
 Drive wheel: Ø10x3"
 Front wheel: Ø4x2.9"
 Stabilizer wheel: Ø3x1.4"
 Handle: CH-2
 Drive Motor: DC24V/0.7KW
 Lift Motor: DC24V/2.0KW
 Battery: 2x12V/95Ah
 Charger: DC24V/6A
 Travel Speed w/load: 3.1m/h
 Travel Speed w/o load: 3.8m/h

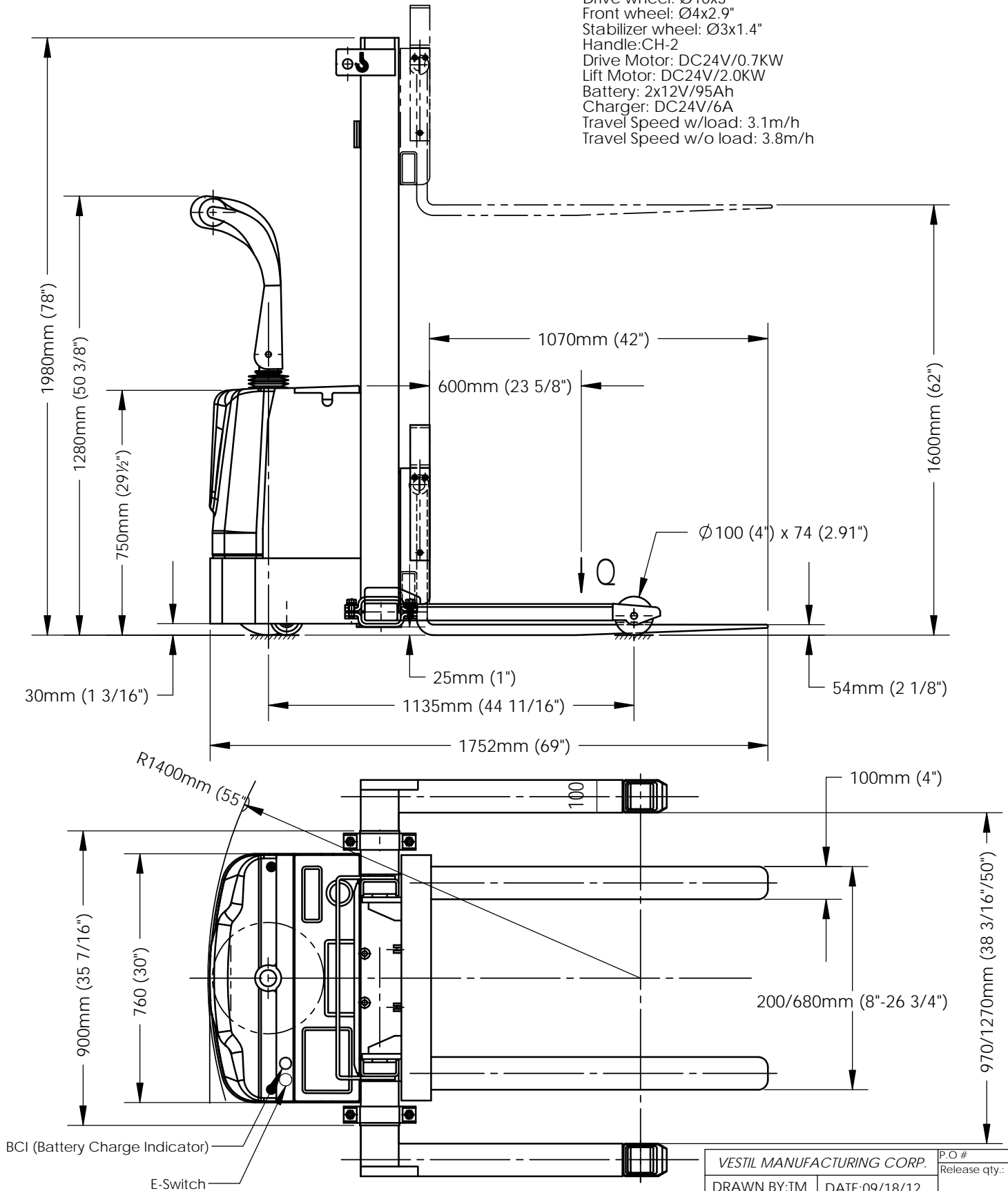

VESTIL MANUFACTURING CORP.		P.O #
DRAWN BY: TM		Release qty.:
DATE: 09/18/12		DRWG./FILE NAME:
Reference:		S-62-AA